



JTA

Aluminum Alloy Bevel Gearbox

Descriptions	001
Materials	001 - 002
Selection Guide	003 - 004
Calculation Formulas	003
Sample Part Number	004
Specifications	005
Overall Dimensions	006
JTA10	006
JTA15	006
JTA20	006
JTA24	006
Other Products	007 - 010
Contact Us	011

Contents



Descriptions

JACTON JTA Series Miniature Bevel Gearboxes are highly precise and powerful lightweight gearboxes. These gearboxes are small-sized, space-saving, ultra-lightweight and in aluminium alloy design. They are lubricated for life to assure trouble free service. High-performance spiral bevel gear is used to enable silent and high transmission operations. The shaft material can employ anti-corrosive stainless steel. Universal mounting type that can be mounted in any direction. When mounting this type gearboxes, use the three mounting holes at the center or the four mounting holes at the flange face.

Key Features

- Compact design, Small sizes, Ultra light weight.
- Gear ratios of 1:1 and 2:1 are actual ones.
- Power Ratings up to 4.94 kW. Torque Ratings up to 40 N.m.
- Gear transmission average efficiency up to 94%.
- 2-way and 3-way configurations.
- Solid shaft as standard
- High efficiency, low backlash, quiet operation, maintenance-free, low running temperature and long service life.

Ambient Conditions

- Installation site: Indoor
- Ambient temperature: -10°C to 50°C
- Humidity: 95% or less
- Altitude: 1,000 m or lower
- Atmosphere: There shall be no corrosive or explosive gas, vapor, and dew condensation, and there shall be minimal dust.

Materials

We use the best materials to guarantee the performance and lifetime of the bevel gearboxes that you purchased.

Housing

- High-strength Aluminum Die-casting (resists corrosion, compact, lightweight, fine).

Spiral Bevel Gears

- High purity rugged alloy steel 20CrMnTi, Carburizing and Quenching, Case Hardened and Lapped in Pairs.

Input Shaft and Output Shaft

- Hardened and tempered alloy steel 40Cr as standard. Custom Stainless Steel SUS304 or SUS316 which has excellent corrosion resistance is adopted for the shaft material.

Bearing

- Equipped with Tapered Roller Bearings with heavy load capacity.

Oil Seals

- Double-lip Oil Seal, High Dust-proof and Oil leak proof.

Lubricants

- Standard lubrication with #3 extra-white high-grade lithium grease, suitable for applications with low input speed and low daily duty cycle.

Materials



Selection Guide

Calculation Formulas

- (01) Gear Ratio = Input Speed (rpm) / Output Speed (rpm)
- (02) Required Output Torque (N.m)
 - Calculate the Corrected Output Torque (N.m) = Required Output Torque (N.m) x fl
 - Calculate the Corrected Output Power (kW) = Required Output Torque (N.m) x Output Speed (rpm) / 9550.
 - Calculate the Input Power (kW) = Output Power (kW) / Efficiency (Gearbox efficiency is 95% after initial running in).

The ratings for bevel gearboxes in this catalogue are based on a service factor of 1.00. For other operating conditions, the application power or torque must be multiplied by the appropriate service factor, to determine the equivalent gear drive power rating. A bevel gearbox should be selected with a rated capacity equal to or greater than the equivalent rating. Below table designates recommended Service Factors for various conditions of load, power source, and duration of service.

• Service Factors fl

Driven Machine Load Characteristic	Operating Time per Day		
	≤ 2 hours	2-10 hours	10-24 hours
Uniform (Light Shocks)	1.00 (1.00)	1.00 (1.25)	1.25 (1.50)
Medium Shocks	1.00 (1.25)	1.25 (1.50)	1.50 (1.75)
Heavy Shocks	1.25 (1.50)	1.50 (1.75)	1.75 (2.00)

- **Note:** please use these data inside the brackets when “frequent starts and stops” refers to more than 10 starts per hour.
- **Note:** time specified for intermittent and occasional service refers to total operating time per day.
- * **Uniform (Light Shocks) driven machine:** generators, conveyor belts, apron conveyor, ventilators, agitators and mixers for uniform densities, filling and packing stations, gear wheel pumps, feed servos of machine tools, filling machines, elevators, light screw conveyors, light conveyor belts, blowers, small agitators, control machines, assembly lines, auxiliary drives for machine tools, centrifuges, packaging machinery.
- * **Medium Shocks driven machine:** lifts, swing gear on cranes, pit ventilators, agitators and mixers for unequal densities, piston pumps, timber processing machines, paper processing machines, winches, auxiliary drives in ships, textile machines, reel winders, plate conveyors, calenders, balancing machines, heavy-duty conveyor belts, sheet metal bending machines, road-building machinery, planing machines, shears, extruders, main drives for machine tools, kneading machines, weaving looms, light table rollers.
- * **Heavy Shocks driven machine:** punches, shears, rolling and smelting machines, heavy-duty centrifuges, heavy-duty supply pumps, edge runners, vibrating machines, cutting machines, brick works machines, heavy-duty lifts, excavators, heavy-duty mixers, presses, muller mixers, rolling mills, heavy-duty table rollers, cold reduction mills, stone crushers, eccentric presses, cutter heads, folding machines, rubber belt conveyors (batch loads), bark peeling drums, run ning gears, punching presses, piston pumps, rotary furnaces, mills, plate filters.

- (03) Duty Cycle per Hour (% Running time) = working time (minutes) ÷ 60 minutes

Selection Guide

Sample Part Number (Example):

JTA10 - 1:1 - 100R - 100R - I-LR - B3
(1) (2) (3) (4) (5) (6)

(1) Model & (2) Gear Ratios

Model	JTA10	JTA15	JTA20	JTA24
Input & Output Shafts Dia.(mm)	10	15	20	24
Gear Ratios	1:1	1:1, 2:1	1:1, 2:1	1:1, 2:1
Max. Torque (N.m)	3.72	7.15	17.74	46.8
Max. Power (kW)	0.31	1.11	1.92	4.94
N.W(kg)	0.45	1.5	3.5	5.5

(3) Input Speed & (4) Output Speed, Below is Sample

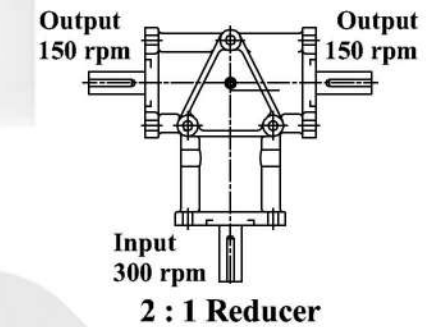
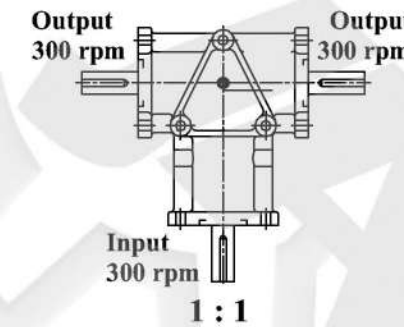

(5) Shaft Arrangements And Rotation Directions

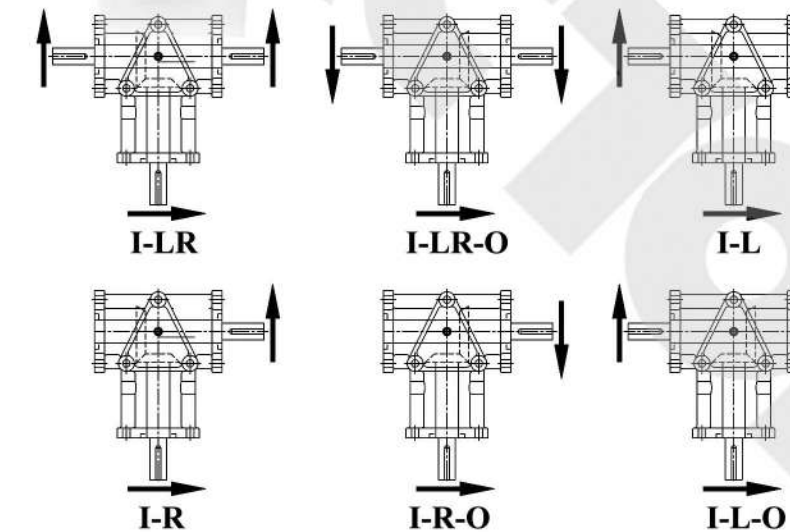

(6) Mounting Positions

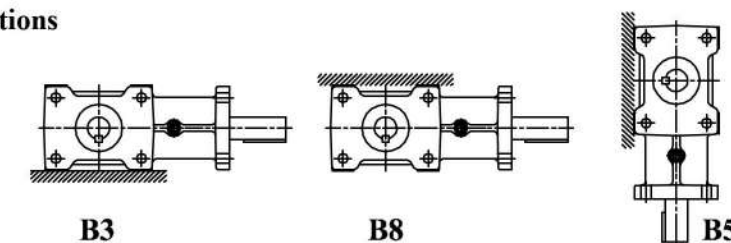

Specifications

Ratio	Input Speed (rpm)	Output Speed (rpm)	JTA10		JTA15		JTA20		JTA24	
			Power (KW)	Torque (Nm)	Power (KW)	Torque (Nm)	Power (KW)	Torque (Nm)	Power (KW)	Torque (Nm)
1:1	1450	1450	0.31	1.96	1.11	7.02	1.92	12.14	4.94	31.23
	1150	1150	0.28	2.23	0.88	7.02	1.73	13.79	4.19	33.40
	870	870	0.24	2.53	0.66	6.96	1.47	15.49	3.46	36.46
	580	580	0.18	2.85	0.44	6.96	1.10	17.39	2.45	38.73
	400	400	0.14	3.21	0.30	6.88	0.76	17.42	1.72	39.42
	300	300	0.12	3.67	0.23	7.03	0.57	17.42	1.30	39.73
	200	200	0.08	3.67	0.15	6.88	0.38	17.42	0.88	40.34
	150	150	0.06	3.67	0.11	6.72	0.28	17.11	0.67	40.95
	100	100	0.04	3.67	0.08	7.15	0.19	17.42	0.45	41.07
	50	50	0.02	3.67	0.04	7.15	0.10	17.42	0.23	42.36
2:1	1450	725			0.55	6.96	0.94	11.89	3.32	41.98
	1150	575			0.43	6.86	0.74	11.80	2.67	42.57
	870	435			0.33	6.96	0.56	11.80	2.04	42.99
	580	290			0.22	6.96	0.37	11.70	1.38	43.63
	400	200			0.15	6.88	0.26	11.92	0.96	44.19
	300	150			0.11	6.72	0.19	11.61	0.73	44.56
	200	100			0.08	6.88	0.13	11.92	0.49	45.11
	150	75			0.06	6.85	0.10	11.96	0.37	45.47
	100	50			0.04	6.97	0.06	11.74	0.25	45.66
	50	25			0.02	6.60	0.03	11.74	0.13	45.84

Overall Dimensions

JTA10

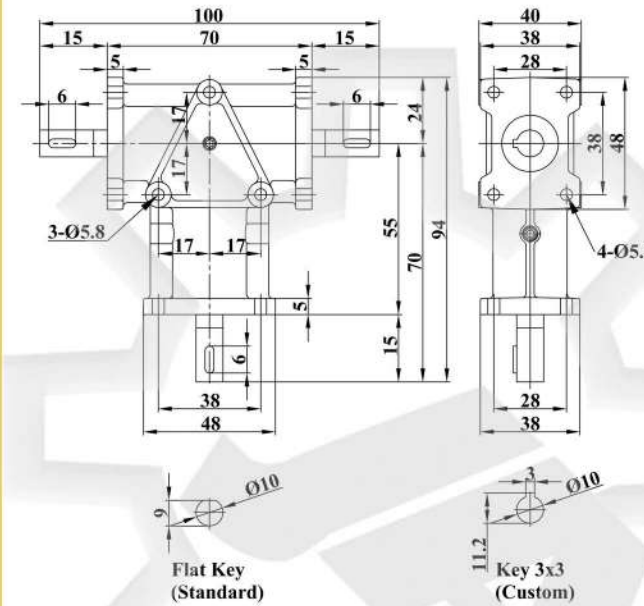

JTA15

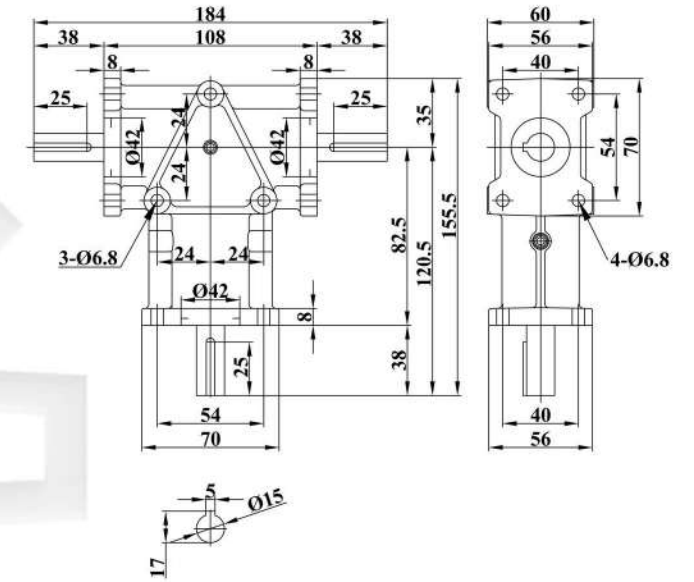

JTA20

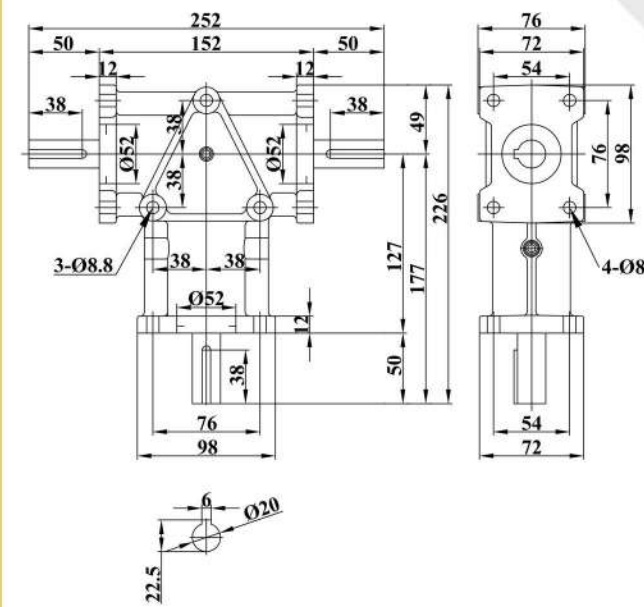

JTA24

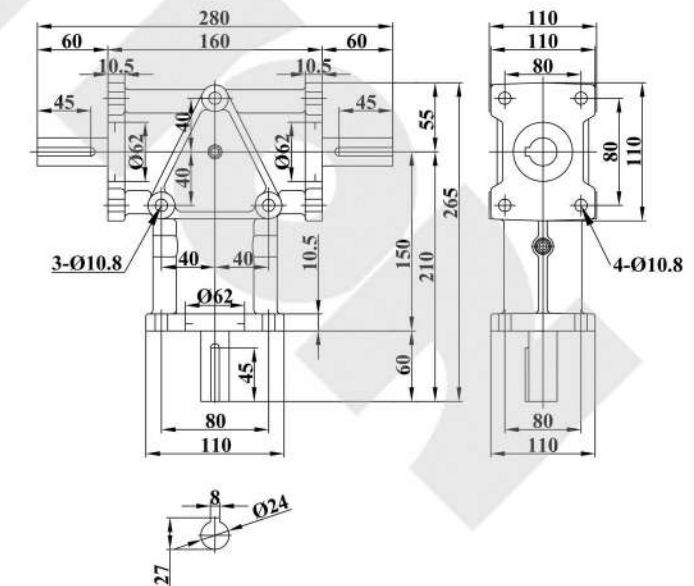

*. Dimensions are subject to change without notice

Other Products

Cubic Machine Screw Jack

- Cubic design permits any mounting position.
- High static loads, best for slow movement and low duty cycles.
- Static load capacities from 2.5 kN to 500 kN as Standard.
- Translating, Anti-rotation (keyed) and Rotating Screw configurations.
- Self locking trapezoidal screw offers maximum stroke of 7500 mm.
- Power source: Manual operation, Motor drive.
- Single jack, or synchronization of multiple jacks arrangement



Cubic Ball Screw Jack

- Cubic design permits any mounting position.
- High duty cycle, high precision, high speed, less power and long service life.
- Static load capacities from 10 kN to 350 kN as Standard.
- Translating, Anti-rotation and Rotating Screw configurations.
- Not self-locking ball screw offers maximum stroke of 6000 mm.
- Power source: Brake motor drive. Not suited for manual operation.
- Single jack, or synchronization of multiple jacks arrangements.



Classic Machine Screw Jack

- Classic design, no need to attach any construction elements to the housing.
- High static loads, best for slow movement and low duty cycles.
- Static load capacities from 0.5 ton to 100 tons as Standard.
- Translating, Anti-rotation (keyed) and Rotating Screw configurations.
- Self locking trapezoidal screw offers maximum stroke of 7500 mm.
- Power source: Manual operation, Motor drive.
- Single jack, or synchronization of multiple jacks arrangements.



Stainless Steel Screw Jack

- Classic design, no need to attach any construction elements to
- Complete Stainless Steel Screw Jack design.
- High static loads, best for slow movement and low duty cycles.
- Static load capacities from 1 ton to 20 tons as Standard.
- Translating, Anti-rotation (keyed) and Rotating Screw configurations.
- Self locking Stainless Steel trapezoidal screw offers maximum stroke of 7500 mm.
- Power source: Manual operation, Motor drive.
- Single jack, or synchronization of multiple jacks arrangements.



Other Products

Classic Ball Screw Jack

- Classic design, no need to attach any construction elements to the housing.
- High duty cycle, high precision, high speed, less power and long service life.
- Static load capacities from 1 ton to 35 tons as Standard.
- Translating, Anti-rotation and Rotating Screw configurations.
- Not self-locking ball screw offers maximum stroke of 6000 mm.
- Power source: Brake motor drive. Not suited for manual operation
- Single jack, or synchronization of multiple jacks arrangements.



Bevel Gear Machine Screw Jack

- High efficiency, high lifting speed, high duty cycle, long lifespan.
- Spiral bevel gear mechanism are used, with 2:1, 2.5:1 and 3:1 ratios.
- Static load capacities from 400 Kg to 3500 Kg as Standard.
- Translating, Anti-rotation (keyed) and Rotating Screw configurations.
- Self locking trapezoidal screw offers maximum stroke of 6000 mm.
- Power source: Manual operation, Motor drive.
- Single jack, or synchronization of multiple jacks arrangement



Bevel Gear Ball Screw Jack

- Higher efficiency, higher lifting speed, higher duty cycle, longer lifespan.
- Spiral bevel gear mechanism are used, with 2:1, 2.5:1 and 3:1 ratios.
- Static load capacities from 400 Kg to 3500 Kg as Standard.
- Translating, Anti-rotation and Rotating Screw configurations.
- Not self-locking ball screw offers maximum stroke of 6000 mm.
- Power source: Brake motor drive. Not suited for manual operation.
- Single jack, or synchronization of multiple jacks arrangements.



Screw Jack Lifting Systems

- Lifting systems are not limited to the number of screw jacks. Commonly used are 2, 4, 6, 8 jack systems.
- Full synchronization, self-locking, precision positioning, easy installation and operation, maintenance free.
- From a few kilograms to heavy-duty several hundred tons.
- Complete lifting systems with geared motors, shafting and couplings available.
- Power source: Synchronized drive from a single electric motor.
- With Inverter driven motor, soft start and stop, variable lifting speeds are all available.



Other Products

Cubic Bevel Gearbox

- Modular design spiral bevel gearboxes with cubic housing.
- Ultra Compact Design. All-round tapped holes for universal mounting, 6 possible mounting positions.
- Gear ratios of 1:1, 2:1, 3:1, 4:1 and 5:1 are actual ones.
- Power Ratings up to 156 kW. Torque Ratings up to 1199 N.m.
- Gear transmission average efficiency up to 94%.
- 2-way, 3-way and 4-way Configurations.
- Solid Shaft, Hollow Shaft, and Direct motor mount or via motor flanges.
- High efficiency, high transmission capacity, low backlash, Noiseless operation, low running temperature and long service life.



Classic Bevel Gearbox

- Used in pairs case hardened alloy steel spiral bevel gears.
- Gear ratios of 1:1, 1.5:1, 2:1, 2.5:1, 3:1, 4:1 and 5:1 are actual ones.
- Power Ratings up to 335 kW. Torque Ratings up to 5713 N.m.
- Gear transmission average efficiency up to 94%.
- 2-way, 3-way and 4-way Configurations.
- Solid Shaft, Hollow Shaft, and Direct motor mount or via motor flanges.
- Various Shafts Arrangements, Rotation Directions and Mounting Positions available.
- High efficiency, high transmission capacity, low backlash, noiseless operation, low running temperature and long service life.



Lightweight Bevel Gearbox (Aluminium Alloy)

- Quality finished casing by die-casting, in lightweight aluminium alloy.
- Compact design, small-sized, ultra-lightweight, universal mounting.
- Utilizing carburized case-hardened spiral bevel gears
- Gear ratios of 1:1 and 2:1 are actual ones.
- Power Ratings up to 4.94 kW. Torque Ratings up to 40 N.m.
- Gear transmission average efficiency up to 94%
- 2-way and 3-way Configurations.
- High efficiency, low backlash, quiet operation, maintenance free, low running temperature and long service life.



Other Products

Electric Cylinders

- Be basically screw jacks with travelling nut, but with lifting cylinder design.
- High static loads, best for slow movement and low duty cycles.
- Static load capacities from 2.5 ton to 10 tons as Standard.
- Self-locking, precise positioning, and uniform speed.
- Power source: Manual operation, Motor drive.
- Single unit, or synchronization of multiple units.
- A better choice over hydraulic actuators or pneumatic cylinders with this clean alternative, simpler to install, control, low maintenance and a quieter solution.



Electric Linear Actuators

- Parallel or In-Line drive configurations.
- Self-locking ACME screw and nut, driven by an electric motor, through a reduction gearbox.
- Low maintenance due to high-quality grease and enclosed design.
- Load capacities from 100 Kgf to 15 tons as Standard (Parallel)
- Load capacities from 10 Kgf to 1000 Kgf as Standard (In-Line).
- Low noise system, higher dynamic capacity, higher speed capability and longer life.
- Low power consumption and running costs, no oil leaks, contamination or fire risk.
- Easy installation with two trunnion mounting feet, no pipework, powerpack and valves.
- Be a real alternative to pneumatic and hydraulic cylinders.



Customized and molded products

